

LINOVECTOR II

LV3-F / LV4-F 14 20 24
Copper/Aluminum and
Steel Element Ratings

Submittal

Specification

LV3 Slip Jointed Enclosure

ENCLOSURE:

STYLE: Flat Top, Front Outlet
OUTLET: Stamped Louvers
Pencil Proof

LENGTHS: 2'0" thru 8'0" in 6" Increments

MAT'L: 16 Ga. CRS (Std)
 14 Ga. CRS (Opt'l)
 16 Ga. Stainless Steel (Opt'l)
 14 Ga. Stainless Steel (Opt'l)
 14 Ga. Aluminum (Opt'l)
 12 Ga. Aluminum (Opt'l)

HEIGHT: 14"
 20" (LV4 only)
 24" (LV4 only)

FINISH: Baked Powder (Std)
 Baked Metallic (Opt'l)

ACCESSORIES:

LV Overlapping Type

All accessories return to the wall at the bottom and have pre-punched holes for fastening to the wall.

LV3-F14

ELEMENT TUBE SIZE	FIN SIZE HEIGHT x WIDTH	CRADLE NUMBER	A
3/4 COPPER	3 1/4 x 3 1/4	2	7"
1" COPPER	3 1/4 x 3 1/4	2	7 3/16"
1 1/4 COPPER	3 1/4 x 3 1/4	1	6 5/8"
1" STEEL	3 1/4 x 3 1/4	2	7 5/16"
1 1/4 STEEL	3 1/4 x 3 1/4	1	6 13/16"

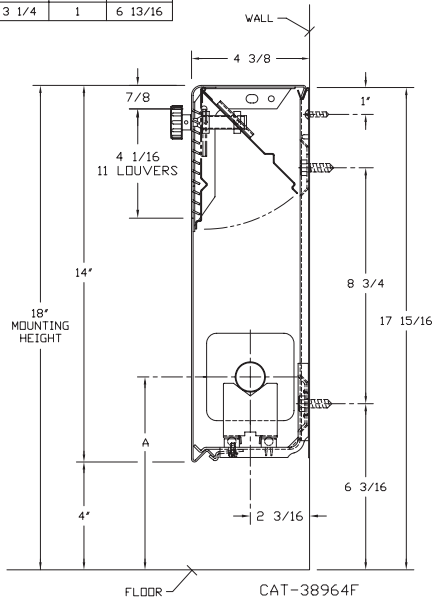

LV4 Slip Jointed Enclosure

BACKPLATE:

TYPE: Partial B/P
LENGTHS: 8'0" Only
MAT'L: 20 Ga. Prepainted (Std)
 18 Ga. Galvannealed (Opt'l)

TYPE: Full Ht. B/P (Opt'l)
LENGTHS: 2'0" thru 8'0" in 6" Increments
MAT'L: 20 Ga. Galvannealed (Opt'l)
 18 Ga. Painted (Opt'l)

AIRSEAL:

1/8" x 3/8" Closed Cell (Opt'l)

BRACKETS:

Water Brkt w/B.B.
 Steam Brkt w/Brkt Mtd
 B.B. Hgr, Bracket Mtd
 B.B. Hgr, Wall Mtd
Wall Mtd B.B. Hgr required for 3rd Tier Element

DAMPER:

Damper Blades Factory Installed
 Knob Damper (Opt'l)
 Tamper Resistant (Opt'l)

LV4-F14 20 24

ELEMENT TUBE SIZE	FIN SIZE HEIGHT x WIDTH	CRADLE NUMBER	A
3/4 COPPER	3 5/8 x 4 1/4	2	7"
3/4 COPPER	4 1/4 x 4 1/4	3A	7 3/8"
1" COPPER	3 5/8 x 4 1/4	2	7 3/16"
1" COPPER	4 1/4 x 4 1/4	2	7 3/16"
1 1/4 COPPER	3 5/8 x 4 1/4	2	7 5/16"
1 1/4 COPPER	4 1/4 x 4 1/4	2	7 5/16"
1" STEEL	4 1/4 x 4 1/4	2	7 5/16"
1 1/4 STEEL	4 1/4 x 4 1/4	2	7 1/2"
2" STEEL	4 1/4 x 4 1/4	1	7 1/4"

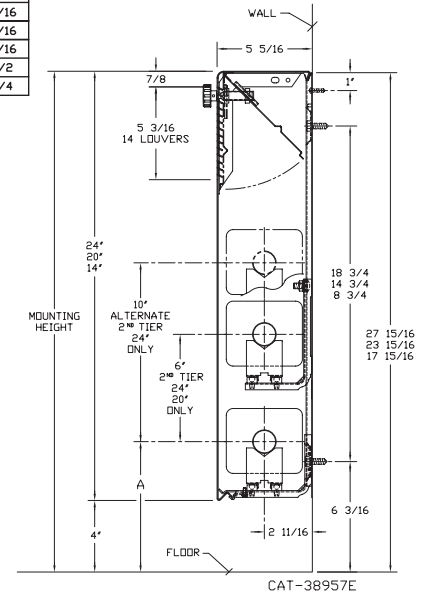

Vulcan

RADIATOR

260 North Elm St., Westfield, MA 01085
(413) 568-9571 Fax: (413) 564-5661
www.vulcanrad.com

PROJECT: _____ DATE: _____

LOCATION: _____

ARCHITECT: _____

ENGINEER: _____

CONTRACTOR: _____

PO NUMBER: _____

STYLE "LV3-F / LV4-F 14 20 24" LINOVECTOR II

COPPER/ALUMINUM ELEMENTS

ALL RATINGS ARE IN BTU/HR/LIN FT AND BASED ON 3 FPS VELOCITY, 65° EAT

TUBE SIZE	CATALOG DESIGNATION	FIN SIZE HEIGHT X WIDTH	FINS PER FT.	FIN THICKNESS IN INCHES	ENCL HEIGHT IN INCHES	TIERS AND CENTERS IN INCHES	MOUNTING HEIGHT IN INCHES	STEAM 215° FACTOR	HOT WATER (AVG.)								
									200°	190°	180°	170°	160°	150°	140°	130°	120°
									CORRECTION FACTORS FOR AVERAGE WATER TEMPERATURES								
								1.00	0.86	0.78	0.69	0.61	0.53	0.45	.40	.33	.26
3/4"	VC3/4-33	3-1/4" SQ.	32	.020	14	1	18	1170	1010	910	810	710	620	530	470	390	300
3/4"	VC3/4-34	3-1/4" SQ.	40	.020	14	1	18	1340	1150	1050	920	820	710	600	540	440	350
3/4"	VC3/4-35	3-1/4" SQ.	50	.020	14	1	18	1480	1270	1150	1020	900	780	670	590	490	380
1"	VC33	3-1/4" SQ.	32	.020	14	1	18	1140	980	890	790	700	600	510	460	380	300
1"	VC34	3-1/4" SQ.	40	.020	14	1	18	1300	1120	1010	900	790	690	590	520	430	340
1"	VC35	3-1/4" SQ.	50	.020	14	1	18	1430	1230	1120	990	870	760	640	570	470	370
1 1/4"	VC133	3-1/4" SQ.	32	.020	14	1	18	1090	940	850	750	660	580	490	440	360	280
1 1/4"	VC134	3-1/4" SQ.	40	.020	14	1	18	1240	1070	970	860	760	660	560	500	410	320
1 1/4"	VC135	3-1/4" SQ.	50	.020	14	1	18	1380	1190	1080	950	840	730	620	550	460	360
3/4"	VC3/4-433	3-5/8" x 4-1/4"	32	.020	14	1	18	1460	1260	1140	1010	890	770	660	580	480	380
					20	1	24	1570	1350	1220	1080	960	830	710	630	520	410
					20	2-6 CL	24	2390	2060	1860	1650	1460	1270	1080	960	790	620
					24	1	28	1620	1390	1260	1120	990	860	730	650	530	420
					24	2-6 CL	28	2410	2070	1880	1660	1470	1280	1080	960	800	630
24	3-6 CL	28	2770	2380	2160	1910	1690	1470	1250	1110	910	720					
3/4"	VC3/4-434	3-5/8" x 4-1/4"	40	.020	14	1	18	1680	1440	1310	1160	1020	890	760	670	550	440
					20	1	24	1790	1540	1400	1240	1090	950	810	720	590	470
					20	2-6 CL	24	2560	2200	2000	1770	1560	1360	1150	1020	840	670
					24	1	28	1870	1610	1460	1290	1140	990	840	750	620	490
					24	2-6 CL	28	2670	2300	2080	1840	1630	1420	1200	1070	880	690
24	3-6 CL	28	3040	2610	2370	2100	1850	1610	1370	1220	1000	790					
3/4"	VC3/4-435	3-5/8" x 4-1/4"	50	.020	14	1	18	1820	1570	1420	1260	1110	960	820	730	600	470
					20	1	24	2080	1790	1620	1440	1270	1100	940	830	690	540
					20	2-6 CL	24	2780	2390	2170	1920	1700	1470	1250	1110	920	720
					24	1	28	2230	1920	1740	1540	1360	1180	1000	890	740	580
					24	2-6 CL	28	2940	2530	2290	2030	1790	1560	1320	1180	970	760
24	3-6 CL	28	3320	2860	2590	2290	2030	1760	1490	1330	1100	860					
1"	VC433	3-5/8" x 4-1/4"	32	.020	14	1	18	1530	1320	1190	1060	930	810	690	610	500	400
					20	1	24	1590	1370	1240	1100	970	840	720	640	520	410
					20	2-6 CL	24	2470	2120	1930	1700	1510	1310	1110	990	820	640
					24	1	28	1640	1410	1280	1130	1000	870	740	660	540	430
					24	2-6 CL	28	2540	2180	1980	1750	1550	1350	1140	1020	840	660
24	3-6 CL	28	2920	2510	2280	2010	1780	1550	1310	1170	960	760					
1"	VC434	3-5/8" x 4-1/4"	40	.020	14	1	18	1760	1510	1370	1210	1070	930	790	700	580	460
					20	1	24	1870	1610	1460	1290	1140	990	840	750	620	490
					20	2-6 CL	24	2640	2270	2060	1820	1610	1400	1190	1060	870	690
					24	1	28	1950	1680	1520	1350	1190	1030	880	780	640	510
					24	2-6 CL	28	2750	2370	2150	1900	1680	1460	1240	1100	910	720
24	3-6 CL	28	3130	2690	2440	2160	1910	1660	1410	1250	1030	810					
1"	VC435	3-5/8" x 4-1/4"	50	.020	14	1	18	1900	1630	1480	1310	1160	1010	860	760	630	490
					20	1	24	2160	1860	1680	1490	1320	1140	970	860	710	560
					20	2-6 CL	24	2600	2240	2030	1790	1590	1380	1170	1040	860	680
					24	1	28	2330	2000	1820	1610	1420	1230	1050	930	770	610
					24	2-6 CL	28	2760	2370	2150	1900	1680	1460	1240	1100	910	720
24	3-6 CL	28	3120	2680	2430	2150	1900	1650	1400	1250	1030	810					
1-1/4"	VC1433	3-5/8" x 4-1/4"	32	.020	14	1	18	1500	1290	1170	1040	920	800	680	600	500	390
					20	1	24	1560	1340	1220	1080	950	830	700	620	510	410
					20	2 @ 6 CL	24	2430	2090	1900	1680	1480	1290	1090	970	800	630
					24	1	28	1600	1380	1250	1100	980	850	720	640	530	420
					24	2 @ 6 CL	28	2500	2150	1950	1720	1530	1330	1130	1000	830	650
24	3 @ 6 CL	28	2880	2480	2250	1990	1760	1530	1300	1150	950	750					
1-1/4"	VC1434	3-5/8" x 4-1/4"	40	.020	14	1	18	1730	1490	1350	1190	1060	920	780	690	570	450
					20	1	24	1850	1590	1440	1280	1130	980	830	740	610	480
					20	2 @ 6 CL	24	2590	2230	2020	1790	1580	1370	1170	1040	850	670
					24	1	28	1910	1640	1490	1320	1170	1010	860	760	630	500
					24	2 @ 6 CL	28	2700	2320	2110	1860	1650	1430	1220	1080	890	700
24	3 @ 6 CL	28	3080	2650	2400	2130	1880	1630	1390	1230	1020	800					
1-1/4"	VC1435	3-5/8" x 4-1/4"	50	.020	14	1	18	1820	1570	1420	1260	1110	960	820	730	600	470
					20	1	24	2070	1780	1610	1430	1260	1100	930	830	680	540
					20	2 @ 6 CL	24	2510	2160	1960	1730	1530	1330	1130	1000	830	650
					24	1	28	2230	1920	1740	1540	1360	1180	1000	890	740	580
					24	2 @ 6 CL	28	2650	2280	2070	1830	1620	1400	1190	1060	870	690
24	3 @ 6 CL	28	2990	2570	2330	2060	1820	1580	1350	1200	990	780					

STYLE "LV3-F / LV4-F 14 20 24" LINOVECTOR II

COPPER/ALUMINUM ELEMENTS

ALL RATINGS ARE IN BTU/HR/LIN FT AND BASED ON 3 FPS VELOCITY, 65° EAT

TUBE SIZE	CATALOG DESIGNATION	FIN SIZE HEIGHT X WIDTH	FINS PER FT.	FIN THICKNESS IN INCHES	ENCL HEIGHT IN INCHES	TIERS AND CENTERS IN INCHES	MOUNTING HEIGHT IN INCHES	STEAM 215° FACTOR	HOT WATER (AVG.)								
									200°	190°	180°	170°	160°	150°	140°	130°	120°
									CORRECTION FACTORS FOR AVERAGE WATER TEMPERATURES								
3/4"	VC3/4-43	4-1/4" SQ.	32	.020	14	1	18	1630	1400	1270	1120	990	860	730	650	540	420
					20	1	24	1680	1440	1310	1160	1020	890	760	670	550	440
					20	2-6 CL	24	2590	2230	2020	1790	1580	1370	1170	1040	850	670
					24	1	28	1720	1480	1340	1190	1050	910	770	690	570	450
					24	2-6 CL	28	2650	2280	2070	1830	1620	1400	1190	1060	870	690
24	3-6 CL	28	3050	2620	2380	2100	1860	1620	1370	1220	1010	790					
3/4"	VC3/4-44	4-1/4" SQ.	40	.020	14	1	18	1900	1630	1480	1310	1160	1010	860	760	630	490
					20	1	24	2190	1880	1710	1510	1340	1160	990	880	720	570
					20	2-6 CL	24	2950	2540	2300	2040	1800	1560	1330	1180	970	770
					24	1	28	2290	1970	1790	1580	1400	1210	1030	920	760	600
					24	2-6 CL	28	3000	2580	2340	2070	1830	1590	1350	1200	990	780
24	3-6 CL	28	3420	2940	2670	2360	2090	1810	1540	1370	1130	890					
3/4"	VC3/4-45	4-1/4" SQ.	50	.020	14	1	18	1950	1680	1520	1350	1190	1030	880	780	640	510
					20	1	24	2230	1920	1740	1540	1360	1180	1000	890	740	580
					20	2-6 CL	24	3012	2590	2350	2080	1840	1600	1360	1200	990	780
					24	1	28	2400	2060	1870	1660	1460	1270	1080	960	790	620
					24	2-6 CL	28	3185	2740	2480	2200	1940	1690	1430	1270	1050	830
24	3-6 CL	28	3600	3100	2810	2480	2200	1910	1620	1440	1190	940					
1"	VC43	4-1/4" SQ.	32	.020	14	1	18	1670	1440	1300	1150	1020	890	750	670	550	430
					20	1	24	1720	1480	1340	1190	1050	910	770	690	570	450
					20	2-6 CL	24	2630	2260	2050	1810	1600	1390	1180	1050	870	680
					24	1	28	1760	1510	1370	1210	1070	930	790	700	580	460
					24	2-6 CL	28	2690	2310	2100	1860	1640	1430	1210	1080	890	700
24	3-6 CL	28	3090	2660	2410	2130	1880	1640	1390	1240	1020	800					
1"	VC44	4-1/4" SQ.	40	.020	14	1	18	1890	1630	1470	1300	1150	1000	850	760	620	490
					20	1	24	2040	1750	1590	1410	1240	1080	920	820	670	530
					20	2-6 CL	24	2730	2350	2130	1880	1670	1450	1230	1090	900	710
					24	1	28	2130	1830	1660	1470	1300	1130	960	850	700	550
					24	2-6 CL	28	2860	2460	2230	1970	1740	1520	1290	1140	940	740
24	3-6 CL	28	3260	2800	2540	2250	1990	1730	1470	1300	1080	850					
1"	VC45	4-1/4" SQ.	50	.020	14	1	18	1980	1700	1540	1370	1210	1050	890	790	650	510
					20	1	24	2260	1940	1760	1560	1380	1200	1020	900	750	590
					20	2-6 CL	24	2660	2290	2070	1840	1620	1410	1200	1060	880	690
					24	1	28	2430	2090	1900	1680	1480	1290	1090	970	800	630
					24	2-6 CL	28	2930	2520	2290	2020	1790	1550	1320	1170	970	760
24	3-6 CL	28	3310	2850	2580	2280	2020	1750	1490	1320	1090	860					
1-1/4"	VC143	4-1/4" SQ.	32	.020	14	1	18	1640	1410	1280	1130	1000	870	740	660	540	430
					20	1	24	1690	1450	1320	1170	1030	900	760	680	560	440
					20	2-6 CL	24	2580	2220	2010	1780	1570	1370	1160	1030	850	670
					24	1	28	1730	1490	1350	1190	1060	920	780	690	570	450
					24	2-6 CL	28	2640	2270	2060	1820	1610	1400	1190	1060	870	690
24	3-6 CL	28	3040	2610	2370	2100	1850	1610	1370	1220	1000	790					
1-1/4"	VC144	4-1/4" SQ.	40	.020	14	1	18	1860	1600	1450	1280	1130	990	840	740	610	480
					20	1	24	2000	1720	1560	1380	1220	1060	900	800	660	520
					20	2-6 CL	24	2680	2300	2090	1850	1630	1420	1210	1070	880	700
					24	1	28	2100	1810	1640	1450	1280	1110	950	840	690	550
					24	2-6 CL	28	2810	2420	2190	1940	1710	1490	1260	1120	930	730
24	3-6 CL	28	3200	2750	2500	2210	1950	1700	1440	1280	1060	830					
1-1/4"	VC145	4-1/4" SQ.	50	.020	14	1	18	1950	1680	1520	1350	1190	1030	880	780	640	510
					20	1	24	2220	1910	1730	1530	1350	1180	1000	890	730	580
					20	2-6 CL	24	2610	2240	2040	1800	1590	1380	1170	1040	860	680
					24	1	28	2400	2060	1870	1660	1460	1270	1080	960	790	620
					24	2-6 CL	28	2870	2470	2240	1980	1750	1520	1290	1150	950	750
24	3-6 CL	28	3240	2790	2530	2240	1980	1720	1460	1300	1070	840					

Note: Copper tube furnished flared one end standard.

STYLE "LV3-F / LV4-F 14 20 24" LINOVECTOR II

STEEL ELEMENTS

ALL RATINGS ARE IN BTU/HR/LIN FT AND BASED ON 3 FPS VELOCITY, 65° EAT

TUBE SIZE	CATALOG DESIGNATION	FIN SIZE HEIGHT X WIDTH	FINS PER FT.	FIN THICKNESS IN INCHES	ENCL HEIGHT IN INCHES	TIERS AND CENTERS IN INCHES	MOUNTING HEIGHT IN INCHES	STEAM 215° FACTOR	HOT WATER (AVG.)								
									200°	190°	180°	170°	160°	150°	140°	130°	120°
									CORRECTION FACTORS FOR AVERAGE WATER TEMPERATURES								
1"	VS33	3-1/4" SQ.	32	.032	14	1	18	990	0.86	0.78	0.69	0.61	0.53	0.45	.40	.33	.26
1"	VS34	3-1/4" SQ.	40	.032	14	1	18	1105	950	860	760	670	590	500	440	360	290
1"	VS35	3-1/4" SQ.	50	.032	14	1	18	1180	1010	920	810	720	630	530	470	390	310
1-1/4"	VS133	3-1/4" SQ.	32	.032	14	1	18	980	840	760	680	600	520	440	390	320	250
1-1/4"	VS134	3-1/4" SQ.	40	.032	14	1	18	1110	950	870	770	680	590	500	440	370	290
1-1/4"	VS135	3-1/4" SQ.	50	.032	14	1	18	1140	980	890	790	700	600	510	460	380	300
1"	VS43	4-1/4" SQ.	32	.032	14	1	18	1380	1190	1080	950	840	730	620	550	460	360
					20	1	24	1430	1230	1120	990	870	760	640	570	470	370
					20	2-6 CL	24	2155	1850	1680	1490	1310	1140	970	860	710	560
					24	1	28	1470	1260	1150	1010	900	780	660	590	490	380
					24	2-6 CL	28	2225	1910	1740	1540	1360	1180	1000	890	730	580
1"	VS44	4-1/4" SQ.	40	.032	14	1	18	1550	1330	1210	1070	950	820	700	620	510	400
					20	1	24	1645	1410	1280	1140	1000	870	740	660	540	430
					20	2-6 CL	24	2330	2000	1820	1610	1420	1230	1050	930	770	610
					24	1	28	1705	1470	1330	1180	1040	900	770	680	560	440
					24	2-6 CL	28	2440	2100	1900	1680	1490	1290	1100	980	810	630
1"	VS45	4-1/4" SQ.	50	.032	14	1	18	1620	1390	1260	1120	990	860	730	650	530	420
					20	1	24	1725	1480	1350	1190	1050	910	780	690	570	450
					20	2-6 CL	24	2385	2050	1860	1650	1450	1260	1070	950	790	620
					24	1	28	1790	1540	1400	1240	1090	950	810	720	590	470
					24	2-6 CL	28	2500	2150	1950	1720	1530	1330	1130	1000	830	650
1-1/4"	VS143	4-1/4" SQ.	32	.032	14	1	18	1260	1080	980	870	770	670	570	500	420	330
					20	1	24	1270	1090	990	880	770	670	570	510	420	330
					20	2-6 CL	24	2030	1750	1580	1400	1240	1080	910	810	670	530
					24	1	28	1280	1100	1000	880	780	680	580	510	420	330
					24	2-6 CL	28	2060	1770	1610	1420	1260	1090	930	820	680	540
1-1/4"	VS144	4-1/4" SQ.	40	.032	14	1	18	1560	1340	1220	1080	950	830	700	620	510	410
					20	1	24	1620	1390	1260	1120	990	860	730	650	530	420
					20	2-6 CL	24	2350	2020	1830	1620	1430	1250	1060	940	780	610
					24	1	28	1660	1430	1290	1150	1010	880	750	660	550	430
					24	2-6 CL	28	2400	2060	1870	1660	1460	1270	1080	960	790	620
1-1/4"	VS145	4-1/4" SQ.	50	.032	14	1	18	1610	1380	1260	1110	980	850	720	640	530	420
					20	1	24	1715	1470	1340	1180	1050	910	770	690	570	450
					20	2-6 CL	24	2340	2010	1830	1610	1430	1240	1050	940	770	610
					24	1	28	1775	1530	1380	1220	1080	940	800	710	590	460
					24	2-6 CL	28	2450	2110	1910	1690	1490	1300	1100	980	810	640
2"	VS242	4-1/4" SQ.	25	.032	14	1	18	1210	1040	940	830	740	640	540	480	400	310
					20	1	24	1220	1050	950	840	740	650	550	490	400	320
					20	2-6 CL	24	1910	1640	1490	1320	1170	1010	860	760	630	500
					24	1	28	1230	1060	960	850	750	650	550	490	410	320
					24	2-6 CL	28	1940	1670	1510	1340	1180	1030	870	780	640	500
2"	VS243	4-1/4" SQ.	32	.032	14	1	18	1380	1190	1080	950	840	730	620	550	460	360
					20	1	24	1420	1220	1110	980	870	750	640	570	470	370
					20	2-6 CL	24	2130	1830	1660	1470	1300	1130	960	850	700	550
					24	1	28	1450	1250	1130	1000	880	770	650	580	480	380
					24	2-6 CL	28	2170	1870	1690	1500	1320	1150	980	870	720	560
2"	VS243	4-1/4" SQ.	32	.032	14	1	18	1380	1190	1080	950	840	730	620	550	460	360
					20	1	24	1420	1220	1110	980	870	750	640	570	470	370
					20	2-6 CL	24	2130	1830	1660	1470	1300	1130	960	850	700	550
					24	1	28	1450	1250	1130	1000	880	770	650	580	480	380
					24	2-6 CL	28	2170	1870	1690	1500	1320	1150	980	870	720	560
2"	VS243	4-1/4" SQ.	32	.032	14	1	18	1380	1190	1080	950	840	730	620	550	460	360
					20	1	24	1420	1220	1110	980	870	750	640	570	470	370
					20	2-6 CL	24	2130	1830	1660	1470	1300	1130	960	850	700	550
					24	1	28	1450	1250	1130	1000	880	770	650	580	480	380
					24	2-6 CL	28	2170	1870	1690	1500	1320	1150	980	870	720	560

- Notes: 1) Steel fins furnished as .032 thick, painted black.
 2) NPT threads furnished on steel elements. Please use domestic fittings for proper installation.
 3) The ends can be provided chamfered for field welded fittings when specified.

Steam Bracket and BB Hanger

ELEMENT TUBE SIZE	FIN SIZE HEIGHT x WIDTH	CRADLE NUMBER	A MIN	A MAX
3/4 COPPER	3 1/4 x 3 1/4	2	7 3/8	9 5/8
1" COPPER	3 1/4 x 3 1/4	2	7 1/2	9 3/4
1 1/4 COPPER	3 1/4 x 3 1/4	1	7"	9 1/16
1" STEEL	3 1/4 x 3 1/4	2	7 5/8	9 3/4
1 1/4 STEEL	3 1/4 x 3 1/4	1	7 3/16	9 3/8

ELEMENT TUBE SIZE	FIN SIZE HEIGHT x WIDTH	CRADLE NUMBER	A MIN	A MAX
3/4 COPPER	3 5/8 x 4 1/4	2	7 3/8	8 3/4
	4 1/4 x 4 1/4	3A	7 11/16	9 1/16
1" COPPER	3 5/8 x 4 1/4	2	7 1/2	8 7/8
	4 1/4 x 4 1/4			
1 1/4 COPPER	3 5/8 x 4 1/4	2	7 5/8	9"
	4 1/4 x 4 1/4			
1" STEEL	4 1/4 x 4 1/4	2	7 5/8	9"
1 1/4 STEEL	4 1/4 x 4 1/4	2	7 7/8	9 1/4
2" STEEL	4 1/4 x 4 1/4	1	7 5/8	9"

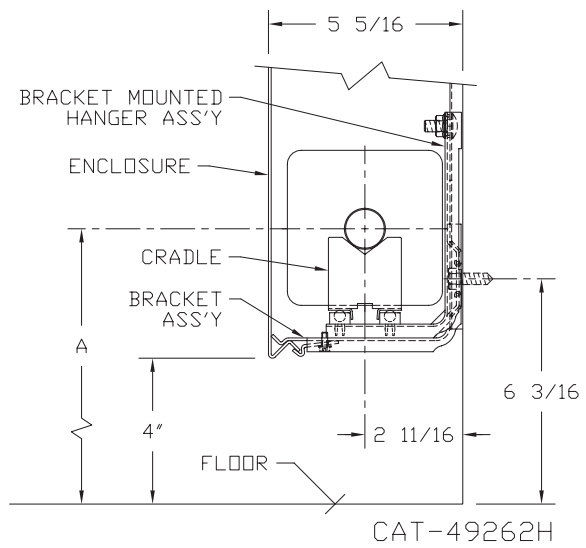
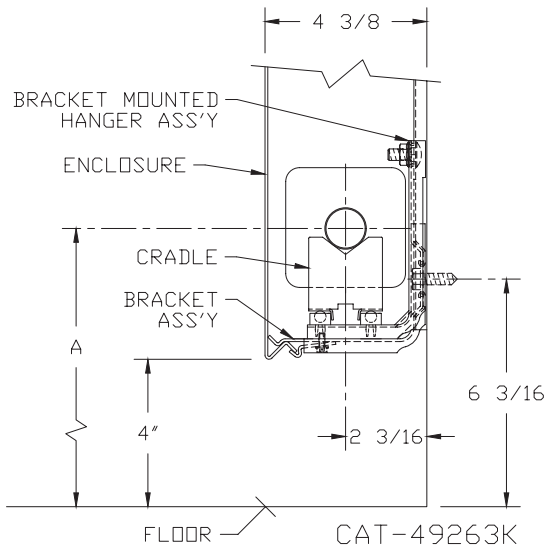

Design Data

COMMERCIAL FINNED TUBE CHARTS FOR RATING CORRECTIONS

For assistance with ratings and selection, please use our online Specifier.

CORRECTION FACTORS FOR WATER TEMPERATURES AND AIR TEMPERATURES OTHER THAN STANDARD															
AVERAGE WATER TEMP. °F	ENTERING AIR TEMPERATURE °F														
	45	55	STD 65	70	75	80	85	90	95	100	110	120	130	140	150
90	.19	.13	.11	.06											
100	.25	.19	.15	.11	.08	.06									
110	.31	.25	.20	.16	.13	.11	.08	.06							
120	.38	.31	.26	.21	.19	.16	.13	.11	.08	.06					
130	.45	.38	.33	.28	.25	.21	.19	.16	.13	.11	.06				
140	.53	.45	.40	.34	.31	.28	.25	.21	.19	.16	.11	.06			
150	.61	.53	.45	.41	.38	.34	.31	.28	.25	.21	.16	.11	.06		
160	.69	.61	.53	.49	.45	.41	.38	.34	.31	.28	.21	.16	.11	.06	
170	.77	.69	.61	.57	.53	.49	.45	.41	.38	.34	.28	.21	.16	.11	.06
180	.86	.77	.69	.65	.61	.57	.53	.49	.45	.41	.34	.28	.21	.16	.11
190	.95	.86	.78	.73	.69	.65	.61	.57	.53	.49	.41	.34	.28	.21	.16
200	1.05	.95	.86	.82	.77	.73	.69	.65	.61	.57	.49	.41	.34	.28	.21
210	1.14	1.05	.95	.91	.86	.82	.77	.73	.69	.65	.57	.49	.41	.34	.28
▶ 215 (STD.)	1.19	1.09	1.00	.95	.91	.86	.82	.77	.73	.69	.61	.53	.45	.38	.31
220	1.24	1.14	1.05	1.00	.95	.91	.86	.82	.77	.73	.65	.57	.49	.41	.34
230	1.34	1.24	1.14	1.09	1.05	1.00	.95	.91	.86	.82	.73	.65	.57	.49	.41
240	1.44	1.34	1.25	1.19	1.14	1.09	1.05	1.00	.95	.91	.82	.73	.65	.57	.49
250	1.55	1.44	1.34	1.29	1.24	1.19	1.14	1.09	1.05	1.00	.91	.82	.73	.65	.57
260	1.66	1.55	1.44	1.39	1.34	1.29	1.24	1.19	1.14	1.09	1.00	.91	.82	.73	.65
270	1.76	1.66	1.55	1.50	1.44	1.39	1.34	1.29	1.24	1.19	1.09	1.00	.91	.82	.73
280	1.87	1.76	1.66	1.60	1.55	1.50	1.44	1.39	1.34	1.29	1.19	1.09	1.00	.91	.82
290	1.99	1.87	1.76	1.71	1.66	1.60	1.55	1.50	1.44	1.39	1.29	1.19	1.09	1.00	.91
300	2.10	1.99	1.87	1.82	1.76	1.71	1.66	1.60	1.55	1.50	1.39	1.29	1.19	1.09	1.00

CORRECTION FACTORS FOR STEAM PRESSURES AND AIR TEMPERATURES OTHER THAN STANDARD																
STEAM		ENTERING AIR TEMPERATURE °F														
PRESSURE		TEMP. °F	45	55	STD 65	70	75	80	85	90	100	110	120	130	140	150
GAUGE	ABS. PSI															
(VAC) 15" HG	7.32	178.9	0.90	0.80	0.70	0.65	0.60	0.56	0.51	0.45	0.39	0.32	0.25	0.18	0.13	0.08
(VAC) 10"	9.78	192.2	1.02	0.91	0.81	0.76	0.71	0.66	0.62	0.55	0.48	0.40	0.33	0.26	0.20	0.14
(VAC) 5"	12.25	202.9	1.11	1.00	0.90	0.85	0.79	0.75	0.70	0.63	0.56	0.48	0.40	0.33	0.27	0.20
▶ 0 PSI	14.696	212.0	1.19	1.09	0.97	0.92	0.87	0.82	0.77	0.70	0.63	0.54	0.46	0.38	0.31	0.25
.899	15.595	215.0	1.22	1.11	1.00	0.95	0.90	0.84	0.80	0.75	0.65	0.57	0.48	0.40	0.33	0.26
5	19.70	227.1	1.34	1.22	1.11	1.05	1.00	0.95	0.90	0.81	0.75	0.66	0.57	0.49	0.41	0.34
10	24.70	239.4	1.45	1.33	1.22	1.17	1.11	1.05	1.00	0.91	0.85	0.75	0.66	0.58	0.50	0.42
15	29.70	249.8	1.55	1.43	1.31	1.26	1.20	1.14	1.09	1.00	0.94	0.84	0.75	0.66	0.57	0.49
20	34.70	258.5	1.63	1.52	1.40	1.33	1.28	1.23	1.17	1.07	1.02	0.92	0.82	0.73	0.64	0.55
25	39.70	266.8	1.71	1.59	1.47	1.41	1.36	1.30	1.25	1.15	1.09	0.98	0.89	0.80	0.71	0.62
30	44.70	274.0	1.78	1.66	1.54	1.48	1.42	1.37	1.31	1.21	1.15	1.05	0.95	0.85	0.76	0.68
40	54.70	286.7	1.91	1.79	1.66	1.61	1.54	1.49	1.43	1.32	1.27	1.16	1.06	0.97	0.87	0.78
50	64.70	297.7	2.02	1.90	1.77	1.71	1.65	1.60	1.54	1.42	1.37	1.26	1.16	1.06	0.96	0.87
60	74.70	307.3	2.10	2.00	1.87	1.81	1.75	1.69	1.63	1.51	1.47	1.35	1.25	1.15	1.05	0.95
70	84.70	316.0	2.20	2.09	1.95	1.89	1.83	1.77	1.71	1.59	1.55	1.44	1.33	1.23	1.12	1.03
80	94.70	323.9	2.27	2.17	2.03	1.97	1.91	1.85	1.80	1.69	1.63	1.52	1.41	1.31	1.20	1.10
90	104.70	331.2	2.36	2.24	2.11	2.05	1.98	1.93	1.87	1.74	1.70	1.59	1.48	1.38	1.28	1.17
100	114.70	337.9	2.43	2.31	2.18	2.11	2.05	2.00	1.94	1.81	1.77	1.65	1.54	1.44	1.33	1.23
125	139.70	352.9	2.59	2.47	2.33	2.27	2.21	2.16	2.10	1.96	1.92	1.80	1.69	1.59	1.48	1.38
150	164.70	365.9	2.73	2.62	2.47	2.43	2.35	2.29	2.23	2.08	2.05	1.94	1.82	1.72	1.61	1.51
175	189.70	377.4	2.86	2.74	2.60	2.54	2.47	2.41	2.35	2.21	2.17	2.05	1.95	1.85	1.73	1.63
200	214.70	387.8	2.95	2.85	2.71	2.63	2.58	2.52	2.47	2.31	2.29	2.17	2.06	1.96	1.84	1.75

From Keenan and Keyes — Linear Interpolation. NOTE: Gauge pressure should be corrected for altitude.

Rate of pitch for steam 1/2" drop over 20-foot run.

Design Data

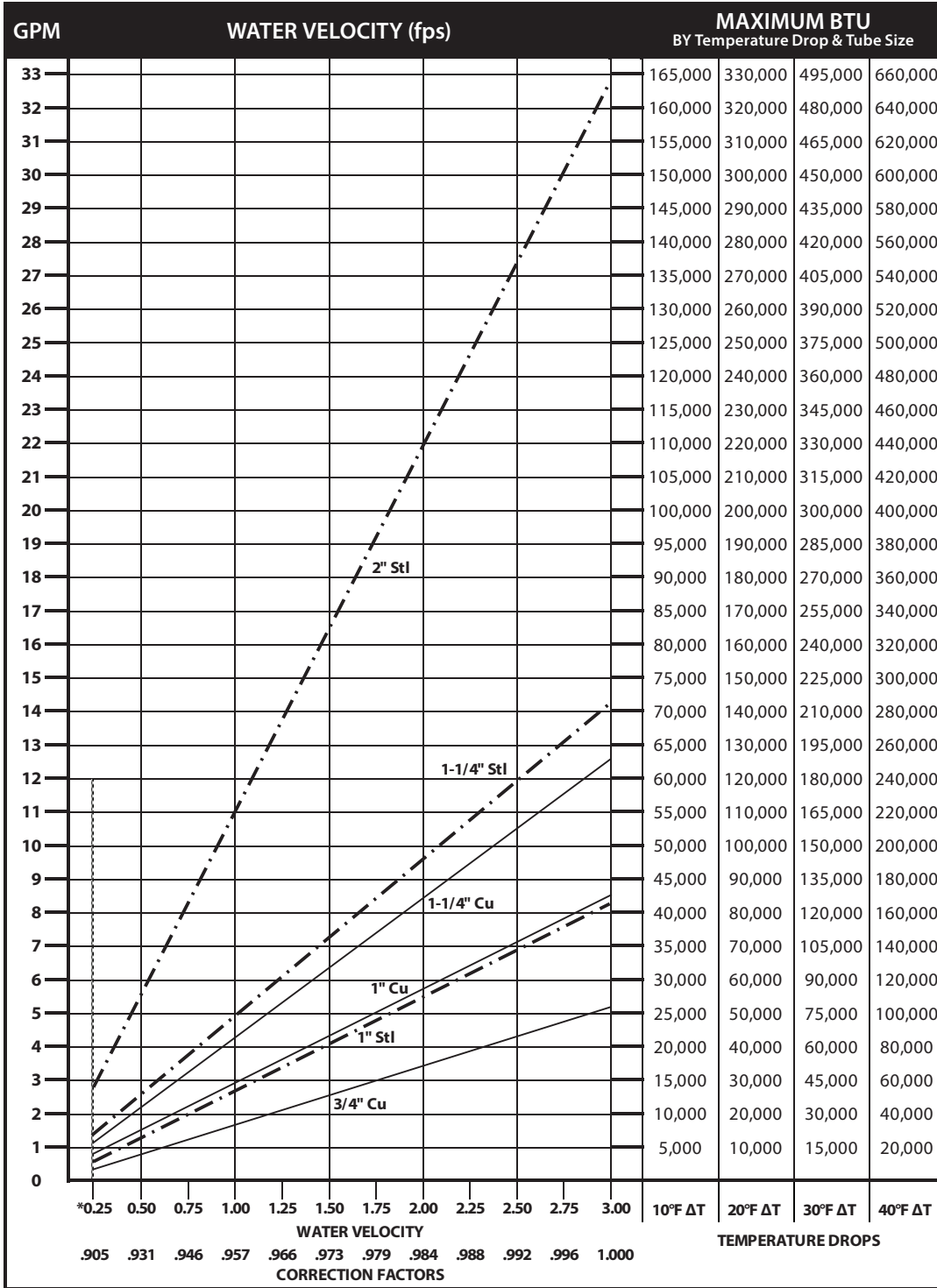

DYNAMIC FORMULAS

$$BTU = GPM \times 500 \times TD$$

$$GPM = \left(\frac{BTU}{500} \right) \div TD$$

$$TD = \left(\frac{BTU}{500} \right) \div GPM$$

*Do not design below .25 fps.

Pressure Drop at Given Water Velocities (Feet of Water per 100 ft. of pipe) based on Hazen - Williams calculation

Nominal Pipe Size	Water Velocity (ft/sec)												
	0.25	0.50	0.75	1.00	1.25	1.50	1.75	2.00	2.25	2.50	2.75	3.00	
3/4" Copper	0.06	0.20	0.42	0.72	1.09	1.53	2.04	2.61	3.25	3.95	4.71	5.53	
1" Copper	0.04	0.15	0.32	0.54	0.81	1.14	1.52	1.94	2.42	2.94	3.50	4.11	
1 1/4" Copper	0.03	0.12	0.25	0.43	0.64	0.90	1.20	1.54	1.92	2.33	2.78	3.26	
1" Steel	0.04	0.15	0.32	0.54	0.81	1.14	1.52	1.95	2.42	2.94	3.51	4.12	
1 1/4" Steel	0.03	0.11	0.23	0.40	0.60	0.84	1.12	1.44	1.79	2.17	2.59	3.05	
2" Steel	0.02	0.07	0.14	0.25	0.37	0.52	0.69	0.89	1.10	1.34	1.60	1.88	

Design Data

GUARANTEED WORKING PRESSURES

- 1" IPS — 780 at Temperatures up to 650°F.
- 1-1/4" IPS — 660 at Temperatures up to 650°F.
- 2" IPS — 405 at Temperatures up to 650°F.
- 1-1/4" CU — 194 at Temperatures up to 300°F.
- 1" CU 204 at Temperatures up to 300°F.
- 3/4" CU 218 PSI at Temperatures up to 300°F.

MAXIMUM PRESSURES AT OTHER TEMPERATURES ARE AVAILABLE UPON REQUEST.

Pipe Water Capacities and Quantities Circulated at Velocity of 3 Feet Per Second

Nominal Pipe Size	Pipe I.D. (inches)	Gals Per Lin. Ft.	GPM @ 3' per sec Velocity
3/4" Copper	0.835	0.028	5.12
1" Copper	1.077	0.047	8.52
1 1/4" Copper	1.315	0.071	12.70
1" Steel	1.075	0.047	8.49
1 1/4" Steel	1.395	0.079	14.29
2" Steel	2.115	0.183	32.85

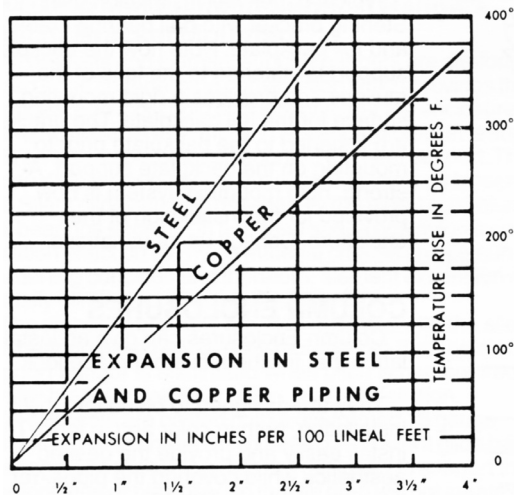

Glycol Correction Factors

Fluid Temperature 200°F

% Solution	Ethylene Glycol	Propylene Glycol
20	.952	.988
30	.921	.968
40	.888	.943
50	.852	.912

Fluid Temperature 180°F

% Solution	Ethylene Glycol	Propylene Glycol
20	.946	.982
30	.913	.961
40	.879	.934
50	.842	.902

Fluid Temperature 140°F

% Solution	Ethylene Glycol	Propylene Glycol
20	.934	.97
30	.898	.946
40	.861	.916
50	.821	.881

INLET VS. OUTPUT/BTUH CAPACITY REDUCTION

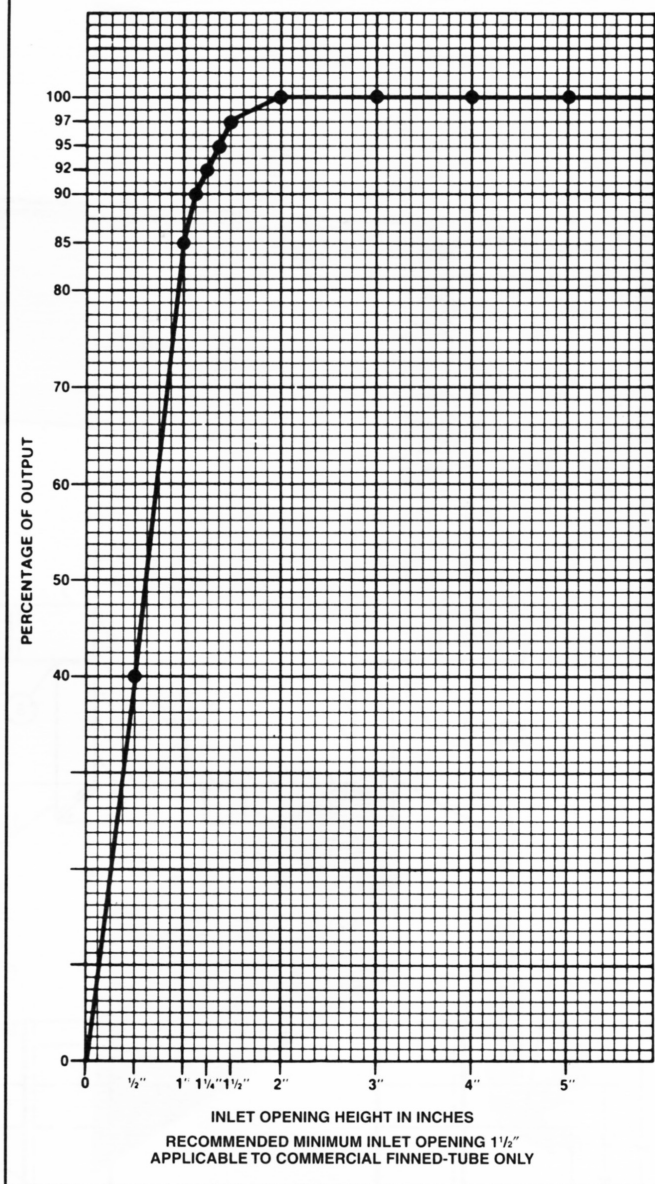

ALTITUDE FACTORS

Approximate factors for convective heat value at varying altitudes

Altitude	Ferrous Units	Copper Alum. Units
Sea Level	1.000	1,000
1,000 ft.	.984	.969
2,000 ft.	.968	.938
3,000 ft.	.952	.908
4,000 ft.	.936	.878
5,000 ft.	.920	.850
6,000 ft.	.904	.822
7,000 ft.	.889	.795
8,000 ft.	.874	.768
9,000 ft.	.859	.743
10,000 ft.	.844	.718
15,000 ft.	.771	.603
20,000 ft.	.703	.502